

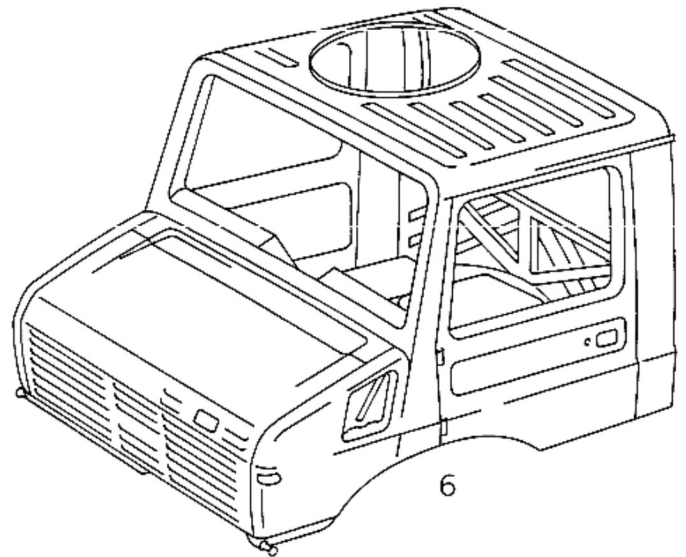

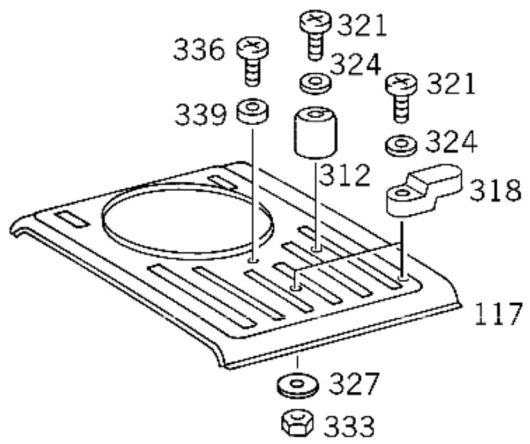

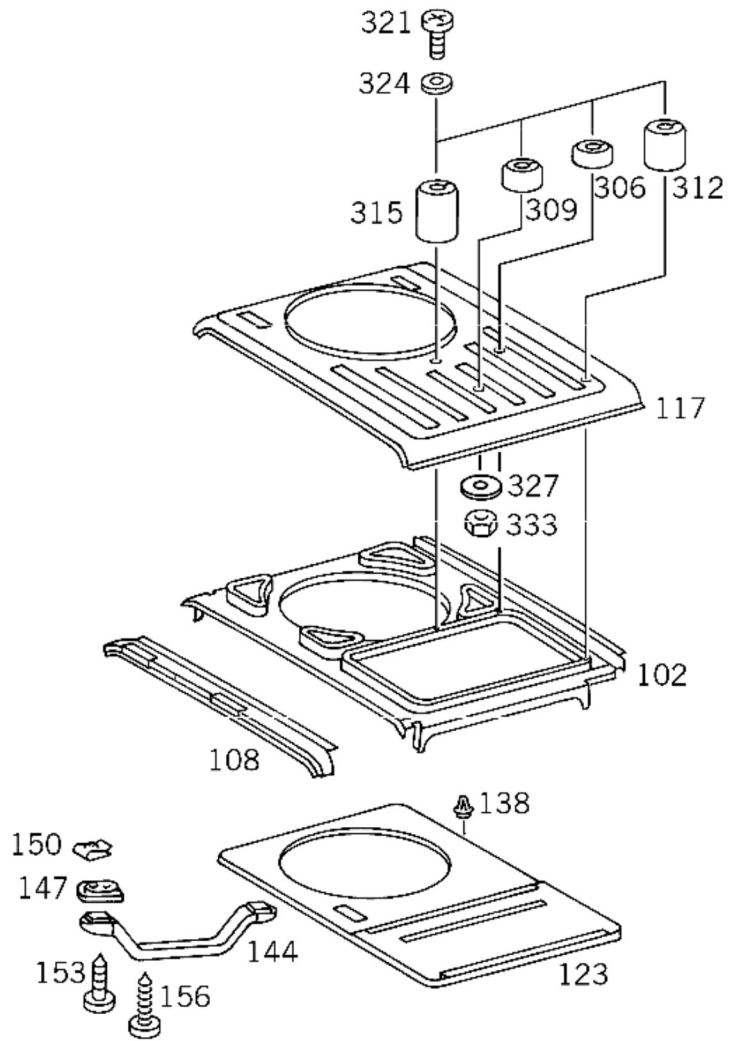



















Unimog > U 1300 L > Aufbau: 425820 > 75 AUSSENKLAPPEN > 53489 DACHKLAPPE RUND





Illustrations-ID: drawing\_S05348900001 Nummer der Zeichnung: 1 / 8













Nur markierte Teile anzeigen  Ersetzte Teilenummern anzeigen

Pos	Teilenummer	Benennung / Zusatzinformationen	LP/NP (EUR)	Menge
6	A 425 600 19 05	ROHBAU Ersetzt durch A 425 600 48 05  SA: 53489 01  [003] ZUSAMMEN MIT :SIEHE MITLIEFERUNGSTEILE		-
6	A 425 600 20 05	ROHBAU Ersetzt durch A 425 600 49 05  SA: 53489 01  [003] ZUSAMMEN MIT :SIEHE MITLIEFERUNGSTEILE		-
6	A 425 600 17 05	ROHBAU Ersetzt durch A 425 600 46 05  SA: 53489 02/03  [003] ZUSAMMEN MIT :SIEHE MITLIEFERUNGSTEILE		-
6	A 425 600 18 05	ROHBAU Ersetzt durch A 425 600 47 05  SA: 53489 02/03  [003] ZUSAMMEN MIT :SIEHE MITLIEFERUNGSTEILE		-
6	A 425 600 48 05	ROHBAU FAHRERHAUS  SA: 53489 01		1
6	A 425 600 49 05	ROHBAU FAHRERHAUS  SA: 53489 01	9.452,95 8.980,30	1
6	A 425 600 46 05	ROHBAU FAHRERHAUS  SA: 53489 02/03	14.648,34 13.915,92	1
6	A 425 600 47 05	ROHBAU Ersetzt durch A 425 600 76 05		-

		 SA: 53489 02/03		
6	A 425 600 76 05	FHS ROHBAU	14.648,34	1
		FAHRERHAUS	13.915,92	
		 SA: 53489 02/03		
		 [402, 409] WIRD NICHT MEHR GELIEFERT		
102	A 425 652 02 65	RAHMENSEGMENT	369,57	1
		 SA: 53489 01/02/03/10	351,09	
102	A 425 652 03 65	RAHMENSEGMENT	367,80	1
		 SA: 53489 01/02/03	349,41	
108	A 425 650 18 01	DACHRAHMEN	166,28	1
		VORN AUSSEN	157,97	
		 SA: 53489 02/03/08		
108	A 425 650 19 01	DACHRAHMEN	167,90	1
		VORN AUSSEN	159,51	
		 SA: 53489 02/03/08		
117	A 425 657 09 09	BEPLANKUNG		-
		Ersetzt durch A 425 650 06 09		
		 SA: 53489 01		
117	A 425 650 06 09	BEPLANKUNG DACH	739,69	1
		 SA: 53489 01/07	702,71	
		 [402] WIRD NICHT MEHR GELIEFERT		
117	A 425 657 10 09	BEPLANKUNG		-
		Ersetzt durch A 425 650 07 09		
		 SA: 53489 01		
117	A 425 650 07 09	BEPLANKUNG DACH	739,69	1
		 SA: 53489 01/07	702,71	

117	A 425 657 07 09	BEPLANKUNG Ersetzt durch A 425 650 04 09   SA: 53489 02/03			-
117	A 425 650 04 09	BEPLANKUNG DACH   SA: 53489 02/03/08		739,69 702,71	1
117	A 425 657 08 09	BEPLANKUNG Ersetzt durch A 425 650 05 09   SA: 53489 02/03			-
117	A 425 650 05 09	BEPLANKUNG DACH   SA: 53489 02/03/08		739,69 702,71	1
123	A 425 695 20 26	VERKLEIDUNG Ersetzt durch A 425 690 01 50  SA: 53489 01/02			-
123	A 425 690 01 50	DACHVERKLEIDUNG Ersetzt durch A 425 690 17 50   SA: 53489 02/03/08			-
123	A 425 690 17 50	DACHVERKLEIDUNG   SA: 53489 02/03/08/10  [903 - 907] Farb-Fußnote			1
123	A 425 690 01 50	DACHVERKLEIDUNG   SA: 53489 01  Werksinformation			1
123	A 425 695 20 26	VERKLEIDUNG Ersetzt durch A 425 690 02 50  SA: 53489 01/02			-
123	A 425 690 02 50	DACHVERKLEIDUNG Ersetzt durch A 425 690 18 50   SA: 53489 02/03/08			-
123	A 425 690 18 50	DACHVERKLEIDUNG   SA: 53489 02/03/08			1

		 [903 - 907] Farb-Fußnote			
123	A 425 690 03 50	DACHVERKLEIDUNG Ersetzt durch A 425 690 19 50			-
		 SA: 53489 01			
		 Werksinformation			
123	A 425 690 19 50	DACHVERKLEIDUNG			1
		 SA: 53489 01/07			
		 Werksinformation			
		 [903 - 907] Farb-Fußnote			
123	A 425 690 04 50	DACHVERKLEIDUNG Ersetzt durch A 425 690 20 50			-
		 SA: 53489 01/07			
		 Werksinformation			
123	A 425 690 20 50	DACHVERKLEIDUNG			1
		 SA: 53489 01/07			
		 Werksinformation			
		 [903 - 907] Farb-Fußnote			
138	A 003 988 41 78	VERKLEID.CLIP		0,90	12
		 SA: 53489 01/02/03		0,81	
		 Werksinformation			
144	A 381 815 00 36	GRIFF		5,75	1
		 SA: 53489 01/02/03/07/08/10		5,46	
147	A 381 695 01 95	ABDECKUNG		1,54	2
		 SA: 53489 01/02/03/07/08/10		1,46	
150	A 000 994 04 45	SICHERUNG Ersetzt durch A 140 994 10 45			-
		 SA: 53489 01/02/03			
150	A 140 994 10 45	SICHERUNG (CLIPSMUTTER)		0,65	2
		 SA: 53489 01/02/03		0,59	
		 Werksinformation			

153	N 007985 005146	SCHRAUBE GRIFF AN DACHVERKLEIDUNG; M5X25	4,96 4,46	4
		 SA: 53489 01/02/03		
		 Werksinformation		
156	N 007516 005105	SCHNEIDSCHRAUBE GRIFF AN DACHVERKLEIDUNG		8
		 SA: 53489 01/02/03/07/08		
		 Werksinformation		
306	A 425 987 01 40	GUMMIPUFFER 23 MM	8,54 7,69	1
		 SA: 53489 02/08/10		
309	A 425 987 02 40	GUMMIPUFFER 27 MM	8,13 7,32	1
		 SA: 53489 02/08		
312	A 425 987 03 40	GUMMIPUFFER 31 MM	7,25 6,53	1
		 SA: 53489 02/03/08/10		
315	A 425 987 50 40	GUMMIPUFFER 40 MM	4,88 4,39	1
		 SA: 53489 02/08/10		
318	A 425 987 51 40	GUMMIPUFFER	14,80 13,32	2
		 SA: 53489 03		
		 [402] WIRD NICHT MEHR GELIEFERT		
321	N 000000 001422	SECHSRUNDSCHR. GUMMIPUFFER AN AUFBAU M6X30	0,86 0,77	4
		 SA: 53489 02/08		
321	N 000000 001422	SECHSRUNDSCHR. GUMMIPUFFER AN AUFBAU M6X30	0,86 0,77	3
		 SA: 53489 03/10		
324	N 000125 006421	SCHEIBE GUMMIPUFFER AN AUFBAU		4

		Ersetzt durch N 000125 006449		
		 SA: 53489 02/03/08		
324	N000125 006449	SCHEIBE	0,43	4
		Ersetzt: N 000125 006421	0,39	
327	N 009021 006208	SCHEIBE	0,61	1
		GUMMIPUFFER AN AUFBAU; 6 MM	0,55	
		 SA: 53489 02/03/08		
333	N 304032 006004	SECHSKANTMUTTER	0,64	1
		GUMMIPUFFER AN AUFBAU; M6	0,58	
		 SA: 53489 02/03/08		
336	N 000000 001145	SECHSRUNDSCHR.	0,44	1
		GUMMIPUFFER AN AUFBAU M6X12	0,40	
		 SA: 53489 03		
339	A 303 997 50 40	DICHTRING	0,83	1
		GUMMIPUFFER AN AUFBAU	0,75	
		 SA: 53489 03		